

iQ
850



THE NEW MULTIFUNCTIONAL COOKING SYSTEM FOR
CATERING

ambach[®]



“

Compact,
flexible and
complete.
Exactly
what I need.

”

The latest innovative and intelligent cooking system from Ambach IQ850 is designed for dynamic kitchens and catering facilities with limited space, but that wish to offer the widest possible menu choices.

At **just 800 mm wide**, this compact, multi-functional and simple to operate cooking system is brimming with our most advanced cooking intelligence and cutting edge technology.

Designed to provide complete cooking flexibility and handle the most diverse menus and work-loads, IQ850 saves time and guarantees **excellent cooking results**, providing complete operational capability to any commercial kitchen.

Thanks to its linear construction this new intelligent and advanced cooking system **can be integrated seamlessly into any configuration** of our Chef 850 equipment range.



FLEXIBILITY



ROBUSTNESS



HYGIENE



CORE PROBE

BUILD UP YOUR KITCHEN



YOUR KITCHEN, JUST THE WAY YOU WANT IT.

Designed to be positioned where you really need it, the IQ850 means you can say goodbye to stand alone braziers in your kitchen. **Reduce your operational footprint by up to 30%** and increase efficiency, cooking flexibility and productivity by placing your multi-functional cooking system right where you need it in your cook line. Create, personalise and evolve your kitchen and menus with the IQ850, together with a complete range of complimentary modular equipment options from our Chef 850 range, including one-piece top executions.

TOTAL FLEXIBILITY, AT YOUR SERVICE.

Setting new standards in catering flexibility and performance, the Ambach IQ850 **multi-zone system** features a duplex compound cooking surface with **two cooking zones** that allow you to cook different foods simultaneously. For precise temperature control the IQ850 has a **core probe** that automatically reads the surface temperature at four different points. From braising to frying, steaming and pasta cooking - as well as low-temperature **overnight applications** - the IQ850 provides a total solution.

MAXIMUM HYGIENE.

As with all units in the Chef 850 range, IQ850 offers the highest levels of hygiene, **reducing both cleaning programmes** and the use of materials to a minimum. The IQ850 achieves this through its **Ambach Assisted Cleaning System (AACS)**, an efficient, semi-automatic cleaning programme that provides operators with a step-by-step process to remove stubborn food deposits. This system, together with a **convenient pullout spray hose**, enables all cooking surfaces to be cleaned easily and effectively, guaranteeing maximum hygiene levels.



Catering for 150-cover "a la carte" restaurants.
A modular cooking block with 5 elements and hygienic seamless joints.

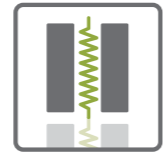

THERMOBLOCKS 2.0



INNOVATION



PERFORMANCE

POWER, EFFICIENCY AND PERFORMANCE



IMPROVED EFFICIENCY THROUGH AMBACH 2.0 THERMOBLOCKS.

The future of flexible cooking has arrived and thanks to a unique system of second generation thermoblocks, the **IQ850 reaches operating temperatures quickly** and provides unrivaled **energy performance**.

Perfect cooking, to satisfy the most discerning of chefs is achieved through even heat distribution on the complete cooking surface. This together with **Power Save**, a unique protection system developed by Ambach, enables the griddle to work effectively at low temperatures, without undergoing thermal shock during the heat up process; allowing the cooking of frozen fish and meats.

MIRRORED SURFACE, BRILLIANT PERFORMANCE.

The innovative IQ850 features a duplex, compound cooking surface with a non-stick finish, meaning the unit can be cleaned quickly and easily prepared to handle different food types. The mirrored surface provides considerable advantages in terms of efficiency, as **it provides even heat distribution and reduces heat dispersion**, ensuring **excellent cooking results** and the **perfect browning** of all meats.

RECORD BREAKING PRODUCTIVITY.

With a power to cooking surface area ratio of **kW/dm² = 0.77** the IQ850 sets a new standard in performance technology.

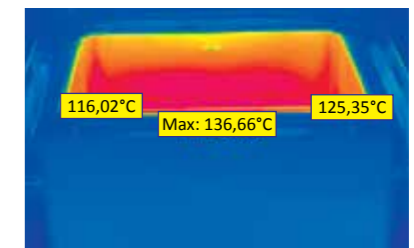

Internal surface temperature distribution.

PERFORMANCE

Ambach IQ850 (Model 8IQ/80)

Omelettes	200/h
Hamburgers	200/h
Goulash (browning without reducing)	56 kg/h
Goulash	17,5 kg/h
Egg pasta (cycles of 10 minutes)	21 kg/h
Chips (9x9 block, not pre-cooked)	35 kg/h
Farro soup with chickpeas	40 kg/h

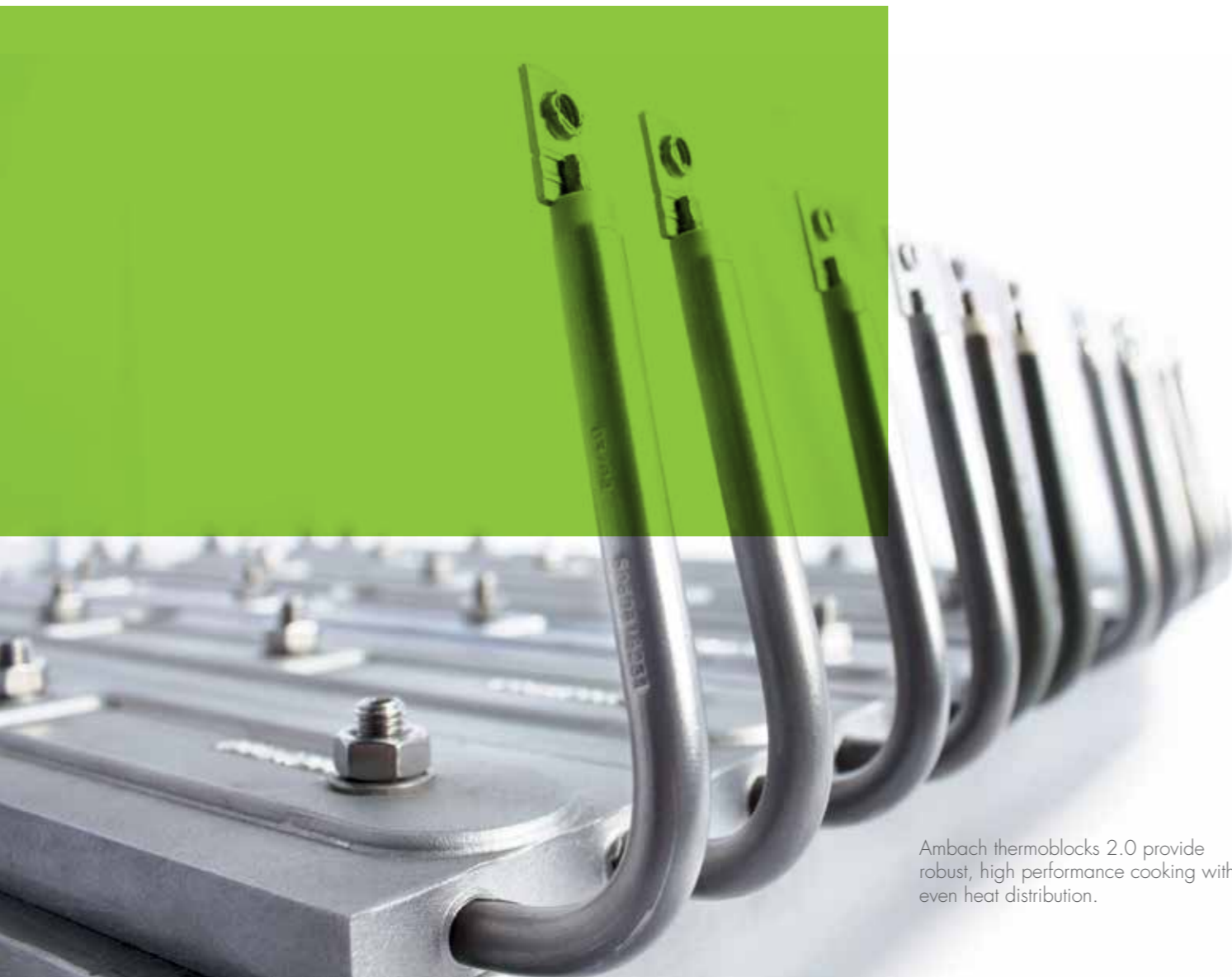

Ambach thermoblocks 2.0 provide robust, high performance cooking with even heat distribution.



FLEXIBILITY



HYGIENE



MIRRORED SURFACE



SAVING



ECO-MODE



THERMOBLOCKS 2.0



ONE-TOUCH



ROBUSTNESS



INNOVATION



PERFORMANCE



AMBACH EASY ACCESS



TROLLEY (OPTIONAL)



CORE PROBE

IQ850, YOUR COMPACT ALLY IN THE KITCHEN.

SUPER COMPACT

- Just 800 mm wide

MODULAR

- Position in a cook-line, or island suite with other complimentary equipment from the Chef 850 equipment range

EASY TO CLEAN

- Hand-held spray hose for manual cleaning
- AACS semi-automatic cleaning programme
- One-piece hygienic top and unique hygienic joining system

MIRRORED COOKING SURFACE

- Excellent heat distribution and maximum cooking performance
- Compound duplex well with mirrored finish and non-stick coating
- Reduced heat dispersion

MULTI-ZONE SYSTEM

- Two independent cooking zones allow you to change quickly from cooking different food types
- Energy efficient heat distribution provides savings of up to 50%

MULTI-FUNCTIONAL OPERATION

- To braise, cook at low temperatures, steam, fry, grill and boil
- Equipped with a multi-well pasta cooker



PLANCHA



COOK



STEAM COOKING



MULTI-ZONE PLANCHA



MULTI-BASKET PASTA COOKER WITH TIMER



FRYER WITH TIMER



CORE PROBE



TROLLEY

- Available on request
- Provides secure loading and transportation

ECO-MODE FUNCTION

- Saves energy when the unit is idle

AMBACH THERMOBLOCKS 2.0

- Improved performance, lower energy consumption
- Specific power kW/dm² = 0.77

AMBACH NAVIGATOR TOUCH SCREEN CONTROL

- Simple and intuitive, one-touch operation
- Raised position: gives the chef greater control, comfort and space
- Heavy-duty touchscreen panel with robust glass
- Clearly visible and legible from anywhere in the kitchen

MANUAL/RECIPE MODES

- Quick settings, excellent results
- Consistent and safe cooking
- Over 30 preset recipes
- Ability to add all your personalised recipes

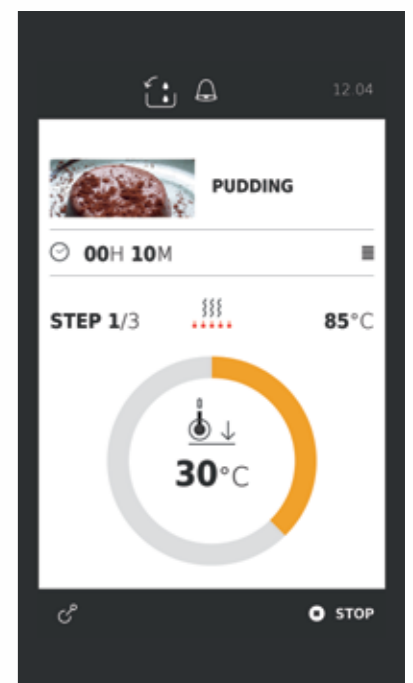



SAVING



ECO-MODE



THERMOBLOCKS
2.0



MIRRORED
SURFACE

ENERGY SAVING



ECO-MODE FUNCTION REDUCES ENERGY WASTE.

The new IQ850 cooking system is powerful, yet energy efficient. Thanks to Eco-Mode, you **save energy** as the unit goes into an idle state **when not in use**, but returns to operating temperature quickly.

LESS ENERGY CONSUMPTION THANKS TO AMBACH THERMOBLOCKS 2.0.

The improved efficiency and effective heat distribution of our second generation thermoblocks reduces energy consumption. The unit's unique **Power Save protection system** allows you to cook at lower temperatures.

MIRRORED BASE, PROVIDES LOW HEAT DISPERSION.

Duplex compound well reduces heat dispersal. Non-stick bottom concentrates energy to the cooking zone and doesn't radiate heat, meaning **less heat dispersal**, providing considerable energy savings and reduced running costs.



An example of a cooking block for a catering kitchen serving 300 people. Three elements in a hygienic one-piece top.



AMBACH
EASY ACCESS



ONE-TOUCH

SINGLE TOUCH START.

The new Ambach Navigator control panel is **simple and intuitive**. There is no need for complex instructions and manuals, simply follow the easy to read icons to operate the IQ850 your way by selecting either manual mode, or via the selection of pre-set recipes and programmes.

MANUAL OR AUTOMATIC, IT'S YOUR CHOICE.

The innovative technology in the Ambach Navigator touch screen control panel offers **an infinite range of cooking options**. You can choose to set your own individual parameters, or follow one of the many recipes suggested by Ambach. With Ambach Navigator you can select the required cooking times and temperatures, or choose from one of **over 200 cooking solutions** in the memory. The control panel allows you to store settings and recipes and make all of the changes you want at any time. In addition, it allows you to activate the semi-automatic Ambach Assisted Cleaning System (AACS).



SEE EVERYTHING AT A GLANCE!

The **ergonomic and robust** design of the Ambach Navigator touch screen control panel, was created to both **maximise and ease the work of chefs** and kitchen personnel. Unlike other machines, the IQ850 is unique as its control panel is not fitted into the surface of the unit. Thanks to its raised position and swivel function the monitor remains **visible from any angle in the kitchen**, giving more freedom of movement to the operator while maintaining complete control over each phase of the cooking process.

QUICK SERVICE, THAT'S A GUARANTEE.

The IQ850 features a hole in the center of the well that allows you to empty the unit quickly and easily when cooking is complete. It is also possible to request a trolley for transportation and distribution.

EASY SERVICING AND MAINTENANCE.

With Ambach equipment, maintenance is never a problem! As with all Ambach products including the complimentary Chef 850 range, servicing is completed easily and quickly. Thanks to our **Easy Access** design innovation, access panels can be removed without the need to move the equipment, even when the unit is inserted into a one-piece hygienic top configuration.

EASY TO USE



TECHNICAL DETAILS

AMBACH IQ850 (MODEL 8IQ/80)

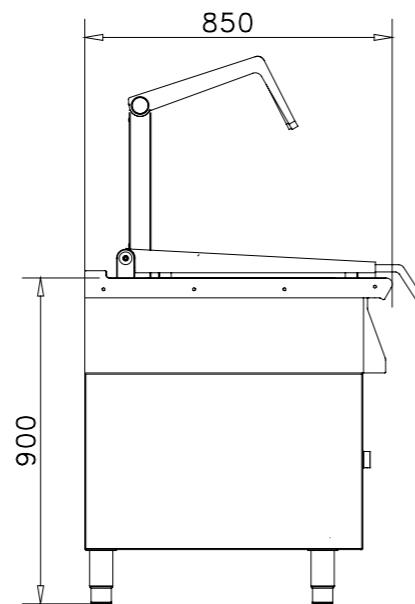
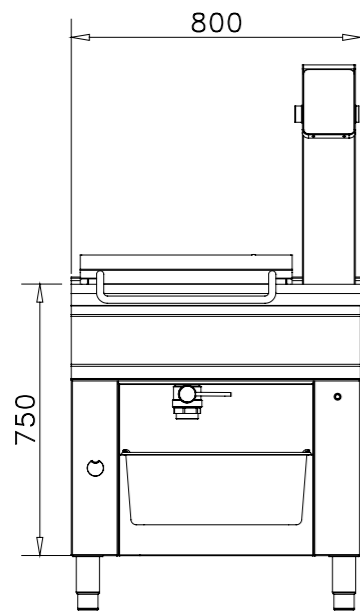

WELL 540 x 540 x 190 mm

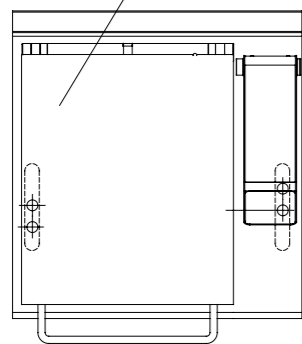

OPTIONAL ACCESSORIES

- TROLLEY
Useful capacity: GN 2/1
Dimensions: 580 x 455 x 435 mm

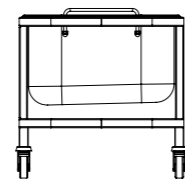

- DETACHABLE SHOWER
- SET OF PERFORATED CONTAINERS
- SET OF BASKETS

Dimensions: 800 x 850 x 900 mm
Power: 22,4 kW (400 V 3 N ~)
Nominal capacity: 55 litres / Useful capacity: 43 litres

ENGLISH

i
900



REDEFINING MULTIFUNCTIONAL
LARGE SCALE COOKING SYSTEMS

ambach[®]



“

Versatile,
efficient
and fast.
It's exactly
what I need.

IQ900 the new multi-functional restaurant cooking system from Ambach is designed for all large-scale food production facilities, including production centers, canteens and hospitals.

Ideal for locations requiring excellent performance and low fuel consumption, this powerful, technologically advanced cooking system ensures the daily production and delivery of **high quality food for large numbers of covers.**

Intelligent, versatile, efficient and fast the IQ900 system automatically manages the cooking processes of boiling, brazing, frying, steaming, pressure and low temperature cooking, including the preparation of roasts and stews.

”

IQ900 easing your workload, delivering excellent results.



FLEXIBILITY



ROBUSTNESS



HYGIENE



CORE PROBE

BUILD UP YOUR KITCHEN



YOUR KITCHEN, JUST THE WAY YOU WANT IT.

The latest innovative, versatile and intelligent cooking system from Ambach, IQ900 is designed for large production kitchens where quality and quantity go hand in hand. Ideal for hospitals and other sizeable operations, the multi-functional IQ900 is brimming with advanced cooking intelligence and cutting edge technology. This simple to operate cooking system, **saves time**, provides complete operational capability and flexibility, **guarantees excellent results** and will handle the heaviest of workloads with ease. **IQ900 can be fully integrated into any System 900 configuration**, including locations where one-piece top executions are required.

POWER AND PERFORMANCE AT YOUR FINGER TIPS.

The power, performance and flexibility of **the IQ900 cooking system significantly improves productivity in any kitchen**. Designed for professional chefs and cooks who need to execute various types of cooking quickly, including brazing, frying, boiling, pressure cooking and low temperature food production. In addition the IQ900's multi-well pasta cooker and **overnight cooking** settings provide additional flexibility.

MAXIMUM HYGIENE.

As with all units in the System 900 range, IQ900 offers the highest levels of hygiene, reducing cleaning programs and the use of materials to a minimum. The IQ900 achieves this through its **Ambach Assisted Cleaning System (AACs)**, an efficient, semi-automatic cleaning program that provides operators with a step-by-step process to remove stubborn food deposits. The AACs system, together with a convenient pullout spray hose enables all cooking surfaces to be cleaned easily and effectively, guaranteeing maximum hygiene levels. And, as the IQ900 can be integrated into a System 900 cook-line with one-piece hygienic top, the unit can be cleaned as a single block.



Example of a catering workstation with a capacity for approximately 400 meals per day.
2 x IQ900, each 2X1/1 GN
2 workbenches with a central electric cooktop.

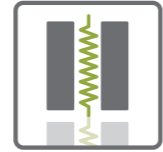

THERMOBLOCKS 2.0



INNOVATION



PERFORMANCE

HIGH POWER



IMPROVED EFFICIENCY THROUGH AMBACH 2.0 THERMOBLOCKS

The future of flexible cooking has arrived and thanks to a unique system of second-generation thermo blocks, **the IQ900 reaches operating temperatures quickly and provides unrivaled energy performance.**

Perfect cooking, to satisfy the most discerning of chefs is achieved through even heat distribution on the complete cooking surface. This together with **Power Save, a unique protection system** developed by Ambach, enables the griddle to work effectively at low temperatures, without undergoing thermal shock during the heat up process; allowing the cooking of frozen fish and meats.

HIGH PERFORMANCE, MIRRORED SURFACE.

The innovative IQ900 features a duplex, compound cooking surface with a non-stick finish, meaning the unit can be cleaned quickly and easily prepared to handle different food types. The mirrored surface provides considerable advantages in terms of efficiency, as **it provides even heat distribution and reduces heat dispersion**, ensuring excellent cooking results and the perfect browning of all meats.

RECORD BREAKING. PRODUCTIVITY.

With a power to cooking surface area ratio of $\text{kW}/\text{dm}^2 = 0.74$, the IQ900 sets a new standard in performance technology.

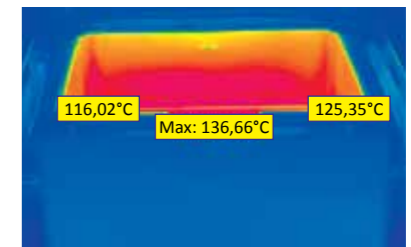

Internal surface temperature distribution.

PERFORMANCE

Ambach IQ900 (Model 9IQ/130)

Omelettes	270/h
Hamburgers	240/h
Goulash (browning without reducing)	12 kg/load
Goulash	60 kg/h (cooking time 60')
Egg pasta (cycles of 10')	35 kg/h
Chips (9x9 block, not pre-cooked)	60 kg/h
Farro soup with chickpeas	80 kg/h

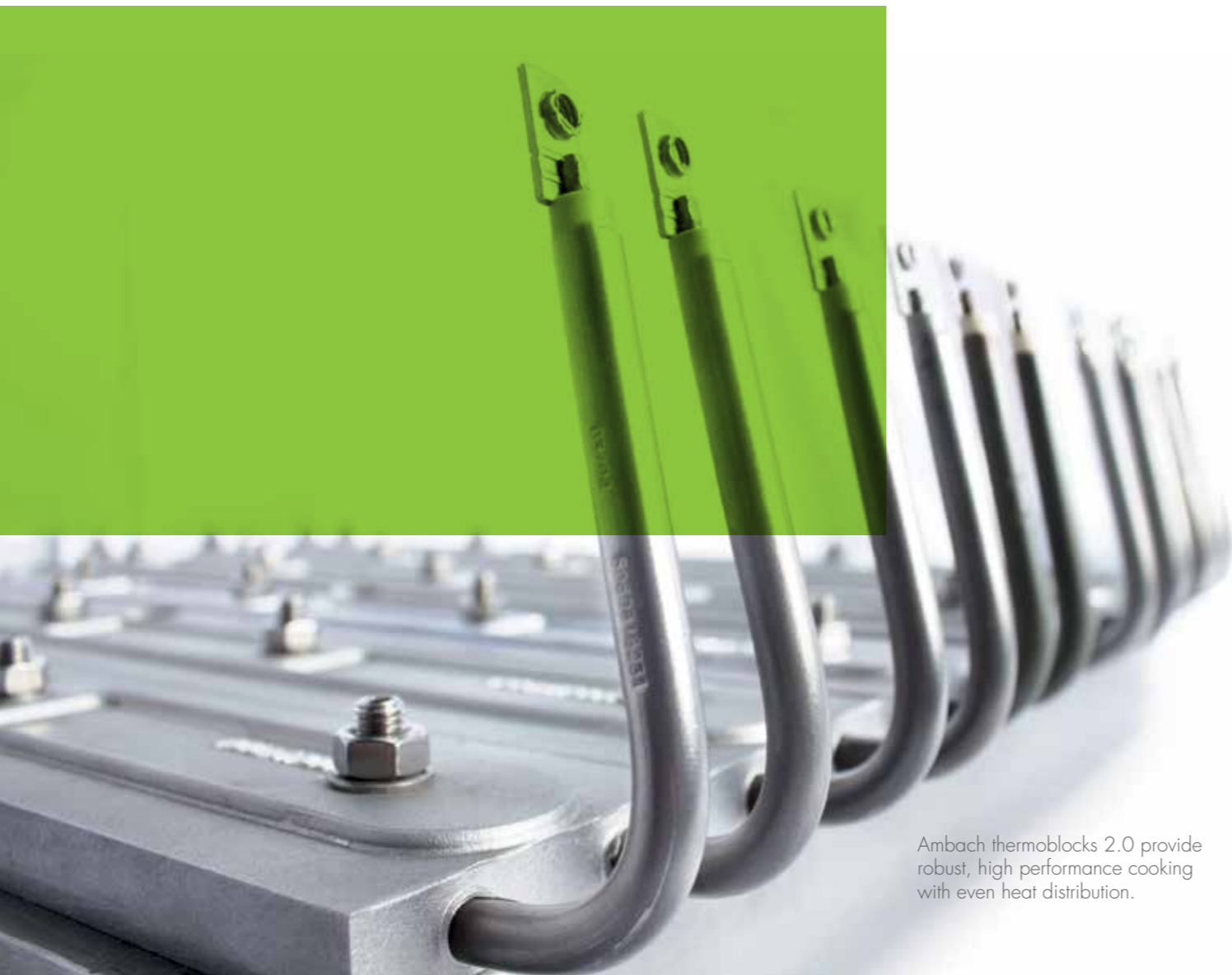

Ambach thermoblocks 2.0 provide robust, high performance cooking with even heat distribution.



FLEXIBILITY



HYGIENE



MIRRORED SURFACE



SAVING



ECO-MODE



THERMOBLOCKS 2.0



ONE-TOUCH



ROBUSTNESS



INNOVATION



PERFORMANCE



AMBACH EASY ACCESS



TROLLEY (OPTIONAL)



CORE PROBE

IQ 900, YOUR PERFECT ALLY IN THE KITCHEN.

POWER = PERFORMANCE

- 27,6 kW in the 91Q/130
- 41,4 kW in the 91Q/165

MODULAR FLEXIBILITY

- Position in a cook-line, or island suite with other complimentary equipment from the System 900 equipment range

EASY TO CLEAN

- Pull-out spray hose for manual cleaning
- One piece hygienic top
- Semi-automatic cleaning program (AACs)

MIRRORED BASE

- Excellent heat distribution, maximum cooking precision
- Anti-stick coating

MULTI-ZONE COOKING SYSTEM

- Total cooking flexibility with energy savings of up to 50%

TROLLEY

- Available on request
- Secure loading and transportation

MULTI-FUNCTIONAL

- Braise, fry, grill and boil. Pressure cook and low temperature cooking.
- Equipped with a multi-well pasta cooker



PLANCHA



COOK



STEAM COOKING



PRESSURE COOKING



MULTI-ZONE PLANCHA



MULTI-BASKET PASTA COOKER WITH TIMER



FRYER WITH TIMER



CORE PROBE



ECO-MODE FUNCTION

- Save energy when the unit is at rest

AMBACH THERMOBLOCK 2.0

- Better performance, lower energy consumption
- Specific power $kW/dm^2 = 0.74$

AMBACH NAVIGATOR TOUCH SCREEN CONTROL

- Simple and intuitive, one-touch operation
- Raised position: gives the chef greater control, comfort and space
- Heavy-duty touch screen panel
- Clearly visible and legible from anywhere in the kitchen

MANUAL/RECIPE MODES

- Quick settings, excellent results
- Consistent and safe cooking
- Over 30 preset recipes
- Ability to add all your personalised recipes

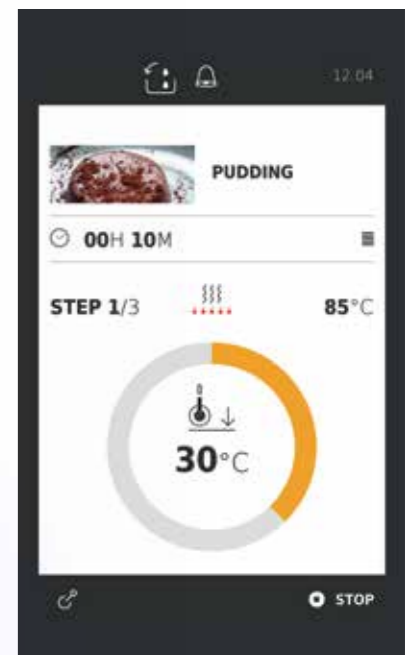



SAVING



ECO-MODE

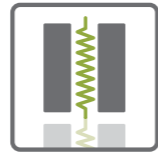

THERMOBLOCKS 2.0



MIRRORED SURFACE

ENERGY SAVING



ECO-MODE FUNCTION REDUCES ENERGY WASTE.

The new IQ900 cooking unit is powerful and **thanks to Eco-Mode you save even more energy**, as the unit goes into an idle state when not in use, but returns to operating temperature quickly.

LESS ENERGY CONSUMPTION THANKS TO AMBACH THERMOBLOCKS 2.0.

The improved efficiency and effective heat distribution of our second generation thermoblocks also reduces energy consumption and the units unique **Power Save protection system** allows you to cook at lower temperatures.

ANTI-STICK COOKING WELL REDUCES HEAT DISPERSAL.

Non-stick surface concentrates energy to the cooking zone and doesn't radiate heat, meaning less heat dispersal, providing considerable energy savings and reduced running costs.



Large production cooking systems by Ambach. IQ900 combined with pot SYS900 in a one-piece hygienic top.



AMBACH
EASY ACCESS



ONE-TOUCH

SINGLE TOUCH START.

The new Ambach Navigator control panel featured on the IQ900 is **simple and intuitive**. With a single touch you can start multiple cooking processes. There is no need for complex instructions and explanations. Simply instruct your personnel to follow the easy to understand icons to set the correct cooking times and organise different activities, whether you're using the manual mode, or by utilising the pre-set recipes.

PROFESSIONAL AND SIMPLE COOKING AT YOUR FINGERTIPS.

Ambach Navigator touchscreen technology enables the control panel to offer **an infinite range of cooking options**. Set your own individual parameters, or simply follow one of the many pre-set recipes. Select cooking times and temperatures of up to 20 different steps, or choose one of **over 200 cooking solutions**. Input and store your settings and recipes. Make any changes you need at any time. It's as simple as that.



SEE EVERYTHING AT A GLANCE!

The ergonomic and robust design of the Ambach Navigator touch screen control panel, was created to both **maximise and ease the work of chefs** and kitchen personnel. Unlike other machines the IQ900 is unique, as its control panel is not fitted into the surface of the unit. Thanks to its raised position and swivel function the monitor remains **visible from any angle in the kitchen**, giving more freedom of movement to the operator, while maintaining complete control over each phase of the cooking process.

QUICK SERVICE, THAT'S A GUARANTEE.

When a cooking process is completed the pan can be emptied easily and quickly. Thanks to a special motorised tilt mechanism, the new IQ900 can be turned over easily, allowing large quantities of food to be served quickly. It is also possible to request a trolley for transportation and distribution.

EASY MAINTENANCE.

With Ambach equipment, maintenance is never a problem! As with the other machines in the Chef 900 line, adjustments are made easily. Thanks to our **Easy Access** design innovation, access panels can be removed without the need to move the equipment, even when the unit is positioned into a one-piece hygienic top configuration.



EASY TO USE





TECHNICAL DETAILS AMBACH IQ900

MODEL 9IQ/130

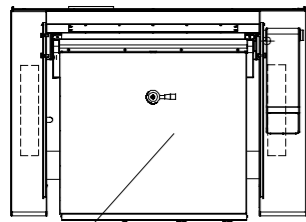
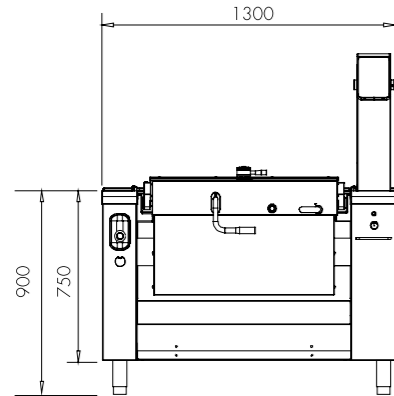

WELL 700 x 550 x 235 mm

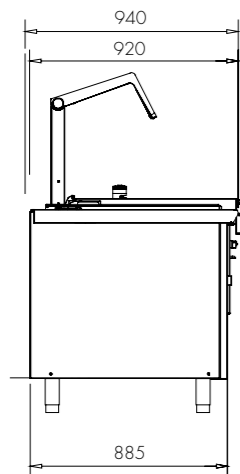

Dimension: 1300 x 920 x 900 mm
Power: 27,6 kW
Nominal capacity: 86 litres / Useful capacity: 70 litres

MODEL 9IQ/165

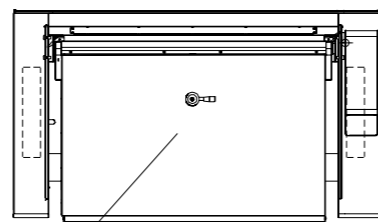
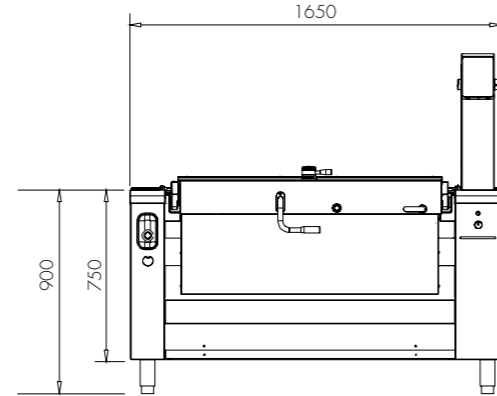

WELL 1050 x 550 x 235 mm

OPTIONAL ACCESSORIES

- TROLLEY
Useful capacity: GN 2/1
Dimensions: 580 x 455 x 435 mm

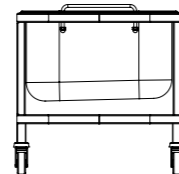

- SET OF PERFORATED CONTAINERS
- SET OF BASKETS

Dimension: 1650 x 920 x 900 mm
Power: 41,4 kW
Nominal capacity: 130 litres / Useful capacity: 105 litres

